



FEHLING Fastening elements and ball joint adapters

Fastening element for ball joint adapter

MZZ-1QFastening element for length- and height-adjustable ball joint adapter, flat

MZZ-1NFastening element for length- and height-adjustable ball joint adapter, small clamping range

Ball joint adapter for retractor system

MRR-5Ball joint adapter for MRP-1 (Ø 4 mm), left

MRP-5.....Ball joint adapter for MRP-1 (Ø 8 mm), left

MRP-5VBall joint adapter for MRP-1 (Ø 8 mm), left

MRR-6Ball joint adapter for MRP-1 (Ø 4 mm), right

MRP-6.....Ball joint adapter for MRP-1 (Ø 8 mm), right

MRP-6VBall joint adapter for MRP-1 (Ø 8 mm), right

MRO-0Ball joint adapter with eccentric lever for fixation to MRP-1 (Ø 4 mm)

MRO-0VBall joint adapter with eccentric lever for fixation to MRP-1 (Ø 4 mm)

HTA-1Ball joint adapter with eccentric lever for fixation to MRP-1 (Ø 6.35 mm)

MRN-9Ball joint adapter with eccentric lever for MICS retractor system (Ø 8 mm)

MRR-1Ball joint adapter for MRR-2/2V/2L/MRP-1 (Ø 8 mm)

MRR-1VBall joint adapter for MRR-2/2V/2L/MRP-1 (Ø 8 mm)

MRR-2Ball joint adapter with spacing lever for blade guide MRN-3 (Ø 4 mm)

MRR-2VBall joint adapter with spacing lever for MRN-3 (Ø 4 mm), 70 mm

MRR-2L Ball joint adapter with spacing lever for MRN-3 (Ø 4 mm), 90 mm

MRR-4 Ball joint adapter with spacing lever (Ø 8 mm)

MRV-1F Ball joint adapter straight (Ø 6.35 mm), variable length and height

MRV-9F Ball joint adapter straight (Ø 4 mm), variable length and height

MRU-8F Ball joint adapter bayonet (Ø 4 mm), variable length and height

MRV-0F Ball joint adapter bayonet (Ø 6.35 mm), variable length and height

MRV-0J Ball joint adapter bayonet with joint, (Ø 6.35 mm), variable length and height

MRV-0R.... Ball joint adapter bayonet with joint (Ø 6.35 mm), variable length and height

MSZ-2..... Ball joint adapter mini (Ø 3.175 mm), front load, variable height

MRX-5 Ball joint adapter mini (Ø 4 mm), front load, variable height

MRV-5 Ball joint adapter 60° angled ball (Ø 8 mm)

MRF-1V Ball joint adapter for round instruments (Ø 8 mm)

Ball joint adapter for long shafts

MTI-3Holder for long shafts (Ø 5 mm), front load

Ball joint adapter for puncture incision

MRO-1Fixation device for MRN-3 atrial retractor

MRO-9Fixation device for MRN-3 atrial retractor, angle-adjustable

MRO-9V....Fixation device for MRN-3 atrial retractor, angle-adjustable

Accessories

LMT-4Cardan screwdriver

TXW-9XAllen screwdriver, 3 mm, sterilisable

MRJ-3Wrench for cloverleaf screws

Slotted screwdriver



These instruments or medical devices are non-sterile when delivered. It is to be reprocessed before use. The instrument must undergo risk assessment according to the RKI Guidelines (non-critical, semi-critical, critical A/B/C) before reprocessing.

The fastening elements and ball joint adapters may only be used, reprocessed and disposed of by qualified medical personnel.

The fastening elements and ball joint adapters are intended for reuse.

1) Intended purpose

The purpose of holding and guiding instruments is to hold or fix products and tissue (e.g. sizers, cotton, swabs, clips, wire, screws, nuts, drills, bone substance, implants, cannulas, drains, holding rods, handles, retractor blades, etc.)

- in or at a specific position

- or to move them into or to a specific position

This excludes retractors (according to IFU retractors Class I and Class IIa), hooks, vessel and tissue clamps, forceps and needle holders.

Additional information regarding the intended purpose

Duration of application: Holding and guiding instruments are intended for short-term use.

Field of application: Holding and guiding instruments are used in all patients where products and tissue must be held or fixed in or to a specific position and/or moved to or in a specific position.

User profile: Holding and guiding instruments may only be used by medically trained personnel (e.g. specialist physician).

Application environment: Holding and guiding instruments are only to be used in controlled environments (e.g. in the operating room).

Target patient population: No restrictions

2) Indications

Treatment methods requiring the holding and guiding of products and tissue.

3) Contraindication

All applications that run counter to the physical and/or mechanical properties of the individual holding and guiding instrument model are contraindicated. There are no generally applicable contraindications for the use of holding and guiding instruments.

Nevertheless, increased risks must be taken into account which could result from the anatomical and physiological conditions as well as the clinical picture of the patient.



4) Possible side effects

The following side effects are described in the medical literature and may also occur during the intended use of holding and guiding instruments:

- Bone fractures, such as ribs, sternum, spinous processes or vertebral bodies
- Infections
- Wound healing disorders
- Lesions of structures (tissue,organs nerves, vessels)
- Necrosis
- Ischaemia
- Hematoma
- Hernia formation



Medical devices may, for example, contain PEEK, chromium, nickel and/or titanium. The materials used are biocompatible, however they may cause allergic reactions or incompatibilities.

5) Before use

The fastening elements and the ball adapters are supplied non-sterile and must be cleaned and sterilised by the user before first use and before each subsequent use (see section 6) *Reprocessing*).



Perform a safety check before each use. Check for sharp edges, cracks, fractures or mechanical malfunctions and missing components (see section 6) *Reprocessing* under "*Maintenance, Inspection and Testing*").



Handle the fastening elements and ball adapters with care during storage, transportation and cleaning.
Avoid striking the fastening elements and ball adapters or applying point loads to them so as not to cause any possible consequential damage. Do not overload functional parts. Do not overstrain functional parts.



Use only sterilised products of sound quality.



Never compress the ball of the ball joint adapter via the wing or hex screw without an instrument inserted into the bore: This could permanently deform the ball and render it only partially usable.

6) Reprocessing



The medical device is to be reprocessed before use. It must undergo risk assessment according to the RKI Guidelines (non-critical, semi-critical, critical A/B/C) before reprocessing.



The national legal regulations, national and international standards and guidelines as well as the company's own hygiene regulations for reprocessing are to be complied with.



| | |
|--|--|
| | <p>The applicable national regulations must be followed for the reprocessing of instruments used in patients with Creutzfeldt-Jakob disease (CJD), suspected CJD or possible variants.</p> |
| | <p>The instruments may only be used, reprocessed and disposed of by qualified medical personnel.</p> |
| | <p>The instruments must be handled with care during storage, transportation and cleaning. Avoid striking the instruments or applying pressure to their parts so as not to cause any consequential damage. Do not overstrain functional parts.</p> |
| | <p>Do not clean instruments with plastic components using oxidative processes (processes with hydrogen peroxide H₂O₂, e.g. Orthovario or Oxivario from Miele). These processes lead to oxidative ageing of the material, which may under certain circumstances not be detectable by visible discolouration or embrittlement.</p> |
| <p>Limitations on re-processing</p> | <p>Frequent reprocessing has little effect on the labelling of the instruments and does not impair their function. The end of product life is normally determined by wear and tear and damage occurring through use (e.g. damage, illegible marking, functional failure - also see "<i>Maintenance, Inspection and Testing</i>").</p> <p>If used and reprocessed correctly, the instruments can demonstrably undergo at least 500 reprocessing cycles.</p> |
| <p>General information on reprocessing</p> | <p>Reprocessing is based on a validated procedure. All the cleaning steps mentioned (manual pre-cleaning, automated/manual cleaning, manual disinfection, and sterilisation) were validated with the respective parameters specified in each case and listed under "Validated procedure". The recommended reprocessing agents (detergent: Neodisher® MediClean forte (Dr. Weigert); disinfectant: Korsolex® med AF (Bode Chemie GmbH)) were used for validation. Both water of potable water quality and fully deionised water (deionised water, demineralised, microbiologically at least of potable water quality) are used for cleaning.</p> <p>Automated reprocessing is preferable to manual cleaning due to a better and safer cleaning result.</p> <p>There is also the option of cleaning our instruments with other tested and approved chemicals which have been recommended by the chemical manufacturer with regard to their material compatibility. Please always observe the manufacturer's information on concentration, exposure time, temperature and renewal of the detergents and disinfectants. All of the chemical manufacturer's instructions for use must be strictly observed. Otherwise, this can lead to visual material changes or material damage, such as, for example, corrosion, fractures or premature ageing.</p> |
| <p>Pre-treatment at the place of use</p> | <p>Pre-cleaning: ensure that blood, tissue and drug residues are removed from the instruments with a disposable cloth/paper wipe immediately after completion of the procedure and that they undergo mechanical cleaning immediately. After completion of initial treatment of the instruments, visual inspections must be performed to ensure that the instruments are complete.</p> <p>The instruments must be transported from the place of use to the place of reprocessing such that neither the user, third parties, the environment nor the medical devices are endangered or damaged (placement in closed, puncture-proof containers and - if necessary - use of protective caps).</p> |



| | |
|------------------------------------|--|
| <p>Preparation before cleaning</p> | <p>Instruments should be reprocessed immediately after use because it is very difficult to remove dried residues from instrument parts that are difficult to access. Do not immerse in normal saline solutions (risk of pitting or stress corrosion).</p> <p>Instruments that were connected to each other during use must be disassembled into their original condition before cleaning.</p> |
| <p>Disassembly</p> | <p>See section 10) <i>Disassembly</i></p> |
| <p>Manual pre-cleaning:</p> | <p><u>Validated procedure:</u></p> <p>Equipment: Basin Soft brush Water spray gun (or similar)</p> <p>Detergent: Neodisher® MediClean forte (Dr. Weigert)</p> <p><u>Procedure/Parameters:</u></p> <ul style="list-style-type: none"> • Rinse instruments, if possible in disassembled condition, under running cold water of potable water quality (< 40 °C) until all visible contamination has been removed. Remove stubborn contamination with a soft brush (not a wire brush). • Cavities, crevices, slits and lumens must be rinsed intensively (> 10 seconds) with cold water (potable water quality, < 40 °C) using a water spray gun (or similar). • Place the products for 10 – 30 minutes in a solution with 0.5 – 2% Neodisher® MediClean forte with water (potable water quality, < 40 °C). • Use only an approved solution of a detergent that has no protein-fixing effect. Follow the instructions of the detergent and disinfectant manufacturer. • Ensure that all areas of the instrument come into contact with the solution. • If necessary, the moving parts of the instrument may be moved back and forth in the cleaning bath. • Remove coarse contamination using a suitable brush (not a wire brush) during the exposure time. • Rinse the instruments for one minute in cold deionised water (see "<i>General Information on Reprocessing</i>") and, if applicable, move movable parts back and forth. |
| <p>Cleaning/Disinfection</p> | <p>If possible, a washer/disinfector according to DIN EN ISO 15883, which uses thermal disinfection, is to be preferred.</p> |
| <p>Cleaning: Automated</p> | <p>Avoid overfilling instrument trays and washing trays - use only suitable instrument holders.</p> <p>When placing instruments in the sterilisation baskets and removing them afterwards, take special precautions to ensure that the tips do not become stuck in the mesh.</p> <p><u>Validated procedure:</u></p> <p>Equipment: Washer/Disinfector G 7835 CD (Miele) / PG 8535 (Miele)</p> <p>Cleaning program: Des-Var-TD (G 7835 CD)</p> |



| | |
|-------------------------------|---|
| | <p>Detergent: Neodisher® MediClean forte (Dr. Weigert)</p> <p><u>Preparation:</u></p> <ul style="list-style-type: none"> • Instruments with joints are to be placed in the device so that the joints are opened or disassembled if possible, and the water can flow from the cavities and blind holes. • If applicable, loosen springs. • Ensure that the area inside all the cavities is also completely rinsed. • Ensure that no areas are left unwashed. • Connect the Luer connectors of the instruments, if present, to the Luer lock rinsing attachment of the washer/disinfector. <p><u>Procedure/Parameters:</u></p> <ul style="list-style-type: none"> • Pre-wash for 3 minutes with cold water (potable water quality, < 40 °C) • Emptying • Clean for 10 minutes with a solution of 0.5 – 2% Neodisher® MediClean forte in water (potable water quality) at 55 °C • Emptying • Rinse for 2 minutes with water (potable water quality, < 40 °C) • Emptying • Rinse for 1 minute with cold deionised water (< 30 °C) • Emptying • Thermodisinfection for 5 minutes with deionised water (> 90 °C) • Dry for 30 minutes (90 °C) <p>After cleaning in the machine, inspect cavities, blind holes, etc. for visible contamination. If necessary, repeat the cycle or clean manually.</p> |
| <p>Cleaning: Manually</p> | <p><u>Validated procedure:</u></p> <p>Equipment: Basin Soft brush Water spray gun (or similar) Bandelin Sonorex Digitec</p> <p>Detergent: Neodisher® MediClean forte (Dr. Weigert)</p> <p><u>Procedure/Parameters:</u></p> <ul style="list-style-type: none"> • Place instruments, if possible in disassembled condition, in cold water (potable water quality, < 40 °C) for 10 minutes. • Move any movable parts, if present, back and forth over the entire range of movement. • Use a soft brush (not a wire brush) to clean the instruments until contamination is no longer visible. • Rinse the instruments for at least 20 seconds using a water spray gun (or similar). <p><u>Ultrasonic cleaning:</u></p> <ul style="list-style-type: none"> • Clean for 10 minutes at < 40 °C with 0.5 – 2% cleaning solution at 35 kHz |



| | |
|--|---|
| | <ul style="list-style-type: none"> • After ultrasonic cleaning, rinse the instruments for at least 20 seconds using a water spray gun (or similar). • Rinse the instruments for at least 10 seconds with water (potable water quality, < 40 °C). • Deionised water (< 40 °C) is to be used for the final rinse. The instruments are rinsed for at least 30 seconds with deionised water. Ensure that no residues remain on the products. |
| <p>Disinfection: Manually</p> | <p>Consult the instructions on the label when selecting a disinfectant (see chemical manufacturer's information).</p> <p><u>Validated procedure:</u> Equipment: Basin Bandelin Sonorex Digitec Disinfectant: Korsolex® med AF (Bode Chemie GmbH)</p> <p><u>Procedure/Parameters:</u></p> <ul style="list-style-type: none"> • After cleaning, place the products in an ultrasonic bath (35 kHz, < 40 °C) with a suitable disinfectant solution (e.g. 0.5% Korsolex® med AF) for 5 minutes. Ensure that all surfaces are wetted with the disinfectant. If applicable, move the moving parts in the disinfection bath before switching on the ultrasonic cleaner. • After disinfection, rinse all products thoroughly with deionised water (< 40 °C) for at least 1 minute to remove the disinfectant and, if applicable, move the moveable parts of the instrument back and forth. • Ensure that no residues remain on the products. • Dry with sterile, oil-free compressed air. |
| <p>Drying</p> | <p>If drying is to be achieved as part of the cleaning/disinfection cycle, do not exceed 120 °C. Then dry with suitable compressed air in accordance with Robert Koch Institute (RKI) recommendations. Pay particular attention to the drying of difficult-to-access areas.</p> |
| <p>Assembly</p> | <p>See section 9) <i>Assembly</i></p> |
| <p>Maintenance, inspection and test- ing</p> | <p>For instruments with movable components that are exposed to friction (e.g. joints), an instrument oil based on paraffin/white oil (according to the valid European or United States Pharmacopoeias) which is biocompatible, steam sterilisable and steam-permeable is to be applied before sterilisation. Such places are additionally marked by a corresponding symbol of an oil can. Instruments must not be treated with care products containing silicone. These can lead to stiffness and impair the effectiveness of steam sterilisation.</p> <p>Perform a safety check of the instruments before each use. When doing so, check for sharp edges, cracks, fractures and mechanical malfunctions and missing components.</p> <p>Check instruments with movable parts for smooth operation (avoid excessive looseness). Check locking mechanisms, if applicable.</p> <p>All instruments: use a magnifying lamp to visually inspect the components for damage and wear and tear.</p> <p>In particular, inspect the critical points on moving parts and in the working area.</p> |



| | |
|---|--|
| | <p>Defective or damaged instruments, or those with illegible markings, must be sorted out and cleaned and disinfected before being returned to the manufacturer. Repairs may only be carried out by the manufacturer or by workshops authorised by the manufacturer. A verification form for this process is available from the manufacturer.</p> <p>Instruments that can no longer be repaired must be disposed of as scrap metal in accordance with hospital practice. In the case of surgical instruments with tips or sharp edges in particular, safe storage in a closed, puncture and break-proof disposable container must be ensured. Do not use damaged instruments.</p> |
| Packaging | <p>Individually: in accordance with the DIN EN 868 series, DIN EN ISO 11607 and DIN 58953.</p> <p>Sets: Sort instruments into dedicated trays or place them in general-purpose sterilisation trays. Pack the trays appropriately using a suitable procedure.</p> |
| Sterilisation | <p>Steam sterilisation in a fractionated vacuum process in a device complying with DIN EN 285 and DIN EN ISO 17665 (Parts 1 and 2). In order to prevent staining and corrosion, the steam must be free of contaminants. The recommended limits for contaminants for feed water and steam condensate are defined by DIN EN 285.</p> <p><u>Validated procedure:</u></p> <p>Equipment: Tuttnauer autoclave Type B 3870 EHS / Lautenschläger ZentraCert</p> <p><u>Procedure/Parameters:</u></p> <p>Cycle type: 3 pre-vacuum phases Sterilisation temperature: 132 – 134 °C Holding time: 4 – 5 minutes Drying time: 20 minutes</p> <p>When sterilising more than one instrument in a sterilisation cycle, do not exceed the maximum load of the steriliser (see manufacturer's instructions).</p> |
| Storage | <p>In accordance with § 4 MPBetreibV (Medical Devices Operator Ordinance) and the standards of the DIN EN 868 series, DIN EN ISO 11607 and DIN 58953.</p> <p>Instruments must be stored dry, at room temperature, clean, protected from damage and mechanical influences (avoid condensation, damage). Always keep instruments, if applicable, in a released state. This counteracts premature fatigue of the spring tension.</p> <p>Instruments must be transported to their place of use in a closed, puncture-proof sterile container.</p> |
| Disposal | <p>These products largely consist of steel. They are to be cleaned before disposal. They can be disposed of at a scrap metal recycling facility. To protect employees, care must be taken to ensure that any pointed tips or sharp edges are protected.</p> |
| <p>The instructions listed above were validated by the medical device manufacturer as suitable for preparing a medical device for reuse. It is the responsibility of the reprocessor to ensure that the reprocessing actually performed using equipment, materials, and personnel in the reprocessing</p> | |



facility achieves the desired result. This requires verification and/or validation and routine monitoring of the process. Likewise, any deviation by the reprocessor from the provided instructions should be carefully evaluated for efficacy and potential adverse consequences.



Any modification to the device or any deviation from these Instructions for Use will result in exclusion of liability.
Subject to change without notice.

7) Configuration and application



Use only sterilised products of sound quality.



Before using the spreaders (retractors) and the spreader components, ensure that the surgical field has been prepared accordingly beforehand.



Before using the medical devices, ensure that their functionality is not impaired and that they are not damaged.



Medical devices made of ferromagnetic materials must not be exposed to either a magnetic field or external electromagnetic influences.



Medical devices containing metals are electrically conductive and must not be exposed to a power source or external electrical influences.



The choice of components depends on the anatomical and physiological conditions as well as the field of application. Care must be taken to ensure that the components used have the correct size and geometry, as well as sufficient stability.

Fastening elements

The fastening element is intended for connection with ball joint adapters that can be attached to the retractor frame with variable height and length.

There are two different variants of fastening elements. Figures 1 and 2 show the respective fastening elements and their distinguishing features.



Fig. 1: MZZ-1N – Fastening element with wing screw and extended screw thread



Fig. 2: MZZ-1Q – Fastening element with wing screw

Table 1 lists the fastening elements with the matching bar height of the retractor frame and the matching ball joint adapters. The ball joint adapters listed are compatible with both fastening elements and are described in detail in the chapter "Ball joint adapters for retractor systems – 1) Ball joint adapter with rail (page 11)". The fastening elements can be used for all retractor frames with a bar height of 3.0 mm or 4.5 mm to 13.0 mm.



Table 1: List of the fastening elements with the matching bar height of the retractor frame and the matching ball joint adapters.

| Item no. | Bar height | Ball joint adapter |
|----------|------------------|--------------------------------------|
| MZZ-1N | 3.0 mm – 13.0 mm | MRU-8F MRV-0F MRV-0J MRV-0R |
| MZZ-1Q | 4.5 mm – 13.0 mm | MRV-1F MRV-9F |

Ball joint adapters

The ball joint adapters, which are available in wide range of variants, serve to accommodate blade guides with round shafts. The ball joint adapters can be placed at any point on the rack, but also on the retractor arms next to the blades if appropriate. Depending on patient anatomy and incision position, the ball can be aligned medially or laterally on the toothed rack.

Each ball joint adapter has a usually U-shaped mount (a) and a fixation device (b) (Fig. 3). This is followed by a clamping bracket (c) with a freely rotating mounted compression ball (d). The round shaft instruments are inserted through the bore of the slotted ball (d) and fixed by means of an adjusting screw (e) which compresses the clamping bracket (c).

The exception is ball joint adapters with a rail, as these require a fastening element to be able to be attached to the retractor frame (see chapter "Fastening elements", page 9).

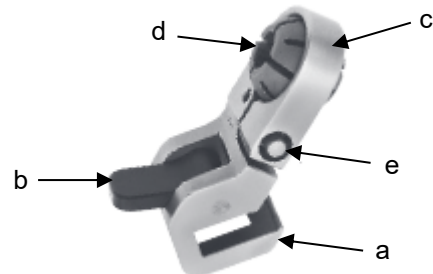

Fig. 3: Structure of an example ball joint adapter

There are many variants of ball joint adapters, which differ in terms of their design features. On the one hand, there are special ball joint adapters that belong to a specific system; on the other hand, there are those that can be used flexibly and independently of the retractor system. These distinguishing features are described below.



Never compress the ball of the ball joint adapter via the wing screw without an instrument inserted into the bore: This could permanently deform the ball and render it only partially usable.



Pay attention to the diameter of the instrument shaft. Ball joint adapters may only be used with the intended shaft diameter, which is indicated on the label.



Medical devices made of ferromagnetic materials must not be exposed to either a magnetic field or external electromagnetic influences.



| Ball joint adapter for retractor systems | | | | | | | | | | |
|---|---|------------------------------|---------|------------------------------|--------|------|--------------------|--------|------|--------------------|
| 1) Ball joint adapter with rail | | | | | | | | | | |
| | For ball joint adapters with a rail, a fastening element is also required, as this variant of ball joint adapter would not attach to the retractor frame by itself. The combinations are listed in Table 1, page 10. | | | | | | | | | |
| <p>Fig. 4: MRV-1F</p> | <p>Ball joint adapter, straight, for accommodating instruments with cylindrical shafts.</p> <table border="1"> <thead> <tr> <th>Item no.</th> <th>Ø in mm</th> <th>Fixation of the movable ball</th> </tr> </thead> <tbody> <tr> <td>MRV-9F</td> <td>4</td> <td>Cardan screwdriver</td> </tr> <tr> <td>MRV-1F</td> <td>6.35</td> <td>Cardan screwdriver</td> </tr> </tbody> </table> | Item no. | Ø in mm | Fixation of the movable ball | MRV-9F | 4 | Cardan screwdriver | MRV-1F | 6.35 | Cardan screwdriver |
| Item no. | Ø in mm | Fixation of the movable ball | | | | | | | | |
| MRV-9F | 4 | Cardan screwdriver | | | | | | | | |
| MRV-1F | 6.35 | Cardan screwdriver | | | | | | | | |
| <p>Fig. 5: MRU-8F</p> | <p>Ball joint adapter in bayonet form for accommodating instruments with cylindrical shafts.</p> <table border="1"> <thead> <tr> <th>Item no.</th> <th>Ø in mm</th> <th>Fixation of the movable ball</th> </tr> </thead> <tbody> <tr> <td>MRU-8F</td> <td>4</td> <td>Cardan screwdriver</td> </tr> <tr> <td>MRV-0F</td> <td>6.35</td> <td>Cardan screwdriver</td> </tr> </tbody> </table> | Item no. | Ø in mm | Fixation of the movable ball | MRU-8F | 4 | Cardan screwdriver | MRV-0F | 6.35 | Cardan screwdriver |
| Item no. | Ø in mm | Fixation of the movable ball | | | | | | | | |
| MRU-8F | 4 | Cardan screwdriver | | | | | | | | |
| MRV-0F | 6.35 | Cardan screwdriver | | | | | | | | |
| <p>Fig. 6: MRV-0J</p> | <p>Fig. 7: MRV-0R</p> | | | | | | | | | |
| <p>Ball joint adapter in bayonet form for accommodating instruments with cylindrical shafts with additional adjustment of the retracting angle.</p> <table border="1"> <thead> <tr> <th>Item no.</th> <th>Ø in mm</th> <th>Fixation of the movable ball</th> </tr> </thead> <tbody> <tr> <td>MRV-0J</td> <td>6.35</td> <td>Cardan screwdriver</td> </tr> <tr> <td>MRV-0R</td> <td>6.35</td> <td>Wing screw</td> </tr> </tbody> </table> | | Item no. | Ø in mm | Fixation of the movable ball | MRV-0J | 6.35 | Cardan screwdriver | MRV-0R | 6.35 | Wing screw |
| Item no. | Ø in mm | Fixation of the movable ball | | | | | | | | |
| MRV-0J | 6.35 | Cardan screwdriver | | | | | | | | |
| MRV-0R | 6.35 | Wing screw | | | | | | | | |
| Configuration example for ball joint adapter with a rail and fastening element | | | | | | | | | | |
| <p>Figure 8 shows, as an example, the configuration of the ball joint adapter MRV-9F (a), which is mounted on the retractor frame MRP-1 (b) with the fastening element MZZ-1Q (c) (see also Section 7, <i>Configuration and Application</i> under “During application,” page 12), and is equipped with a holder for the septal fold and the diaphragm MRU-6 (d) with a cylindrical shaft.</p> | | | | | | | | | | |
| | <p>The rail of the ball joint adapter and the fastening element are loosely pushed onto each other. When handling, care must be taken to hold both parts to prevent unintentional slippage and falling of a part.</p> | | | | | | | | | |



During application

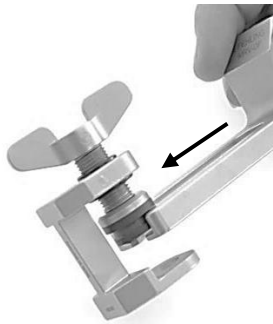

Fig. 9a

Lateral view:
Insertion of the fastening element into the ball joint adapter rail



Fig. 9b

Connection with retractor arm



Fig. 9c

Fixation by turning the wing screw of the fastening element clockwise



The rail of the ball joint adapter and the fastening element are loosely pushed onto each other. When handling, care must be taken to hold both parts to prevent unintentional slippage and falling of a part.

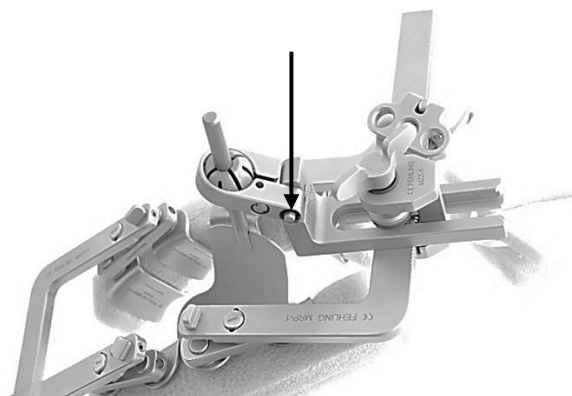

Fig. 10a: Operation of the ball joint adapter with hexagon screw

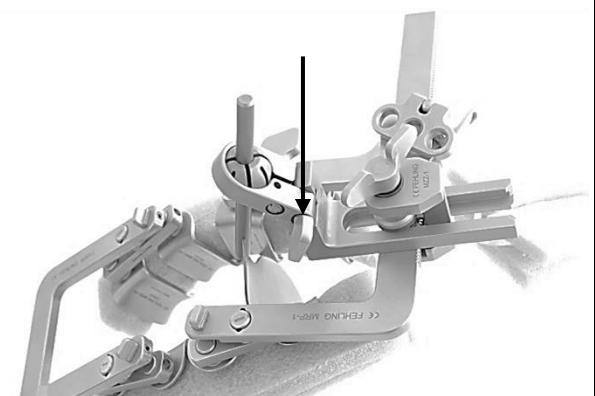

Fig. 10b: Operation of the ball joint adapter with wing screws



A cardan screwdriver is required for the application of ball joint adapters with hexagon screws (Fig. 10a) (see section 8) *Required accessories*).
A cardan screwdriver is not required for the application of ball joint adapters with wing screws (Fig. 10b).



2) Ball joint adapter with adjustable fixation



Fig. 11: MRF-1V

Ball joint adapter for accommodating instruments with cylindrical shafts with additional adjustment of the retracting angle. The ball joint adapter consists of a U-shaped profile that can be attached to rectangular retractor frames of different heights. The ball joint adapter is attached by means of a compression screw.

| Item no. | Ø in mm | Fixation of the movable ball |
|----------|---------|------------------------------|
| MRF-1V | 8 | Wing screw |

Configuration example for the ball joint adapter with adjustable fixation

Figure 12 shows the ball joint adapter MRF-1V (a) in connection with the blade guide MRF-0V (b) on a sternum retractor MNS-1 (c).

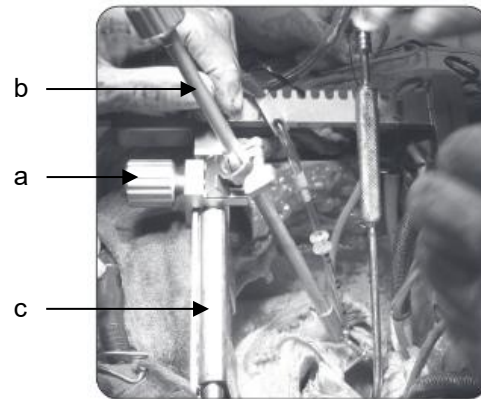

Fig. 12: Configuration example for MRF-1V

3) Ball joint adapter mini



Fig. 13: MRX-5

Ball joint adapter (mini) for frontal accommodation of instruments with cylindrical shafts. The ball joint adapter consists of a U-shaped profile that can be attached to retractor frames of different heights. The ball joint adapter is attached by means of a pressure screw, which is tightened with a hexagonal Allen key (accessory: TXW-9X Allen screwdriver see section 8) *Required accessories*).

| Item no. | Ø in mm | Fixation of the movable ball |
|----------|---------|------------------------------|
| MSZ-2 | 3.175 | Wing screw |
| MRX-5 | 4 | Wing screw |



Configuration example for ball joint adapter mini

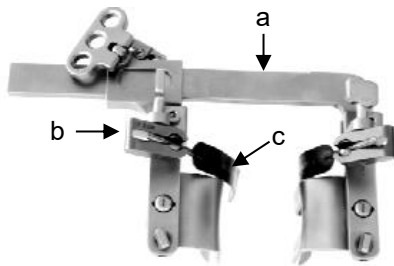

Fig. 14a: Configuration example for MSZ-2 from anterior view

Figures 14a and 14b show the ball joint adapters MSZ-2 (b) mounted on both arms of an MICS intercostal retractor MRP-1 (a) from two different angles. They are each equipped with a spatula with cylindrical shaft (c), such as the EOL-1/2/3/4/5 or the EOM-1/2/3/4/5.

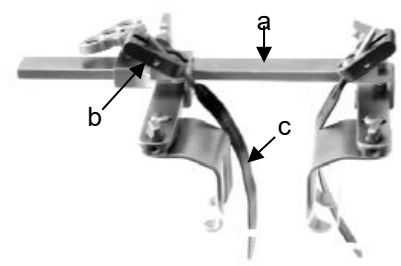

Fig. 14b: Configuration example for MSZ-2 from lateral view

Figure 15 shows the ball joint adapter MRX-5 (b), also mounted on a MICS intercostal retractor MRP-1 (a), equipped with a SUPERPLAST retractor (Ø 4 mm) MRX-1V (c) for retraction of the anterior MV cusp.

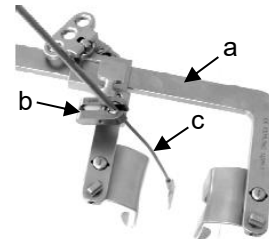

Fig. 15: Configuration example for MRX-5

4) Ball joint adapter for sliding onto the retractor arm



Fig. 16: MRP-5V



Fig. 17: MRP-6V

Ball joint adapter for accommodating instruments with cylindrical shafts. For attachment to the FEHLING MICS intercostal retractor MRP-1. Fixation of the ball joint adapter via the latch attached to the retractor arm. It must be aligned parallel to the retractor arm. The ball joint adapter is pushed onto the end of the retractor arm with the slot provided for this purpose and the latch is rotated 90° so that the connection is securely fixed.

| Item no. | Ø in mm | Fixation of the movable ball |
|----------------|---------|------------------------------|
| MRR-5 (left) | 4 | Cardan screwdriver |
| MRR-6 (right) | 4 | Cardan screwdriver |
| MRP-5V (left) | 8 | Cardan screwdriver |
| MRP-6V (right) | 8 | Cardan screwdriver |
| MRP-5 (left) | 8 | Wing screw |
| MRP-6 (right) | 8 | Wing screw |



Example configuration for ball joint adapter for sliding onto the retractor arm

Figure 18 shows keeping the incised atrium open. For this purpose, the ball joint adapter MRP-6V (a) was connected to the FEHLING MICS intercostal retractor MRP-1 (b) and equipped with a blade guide MRF-0V with cylindrical shaft (c).

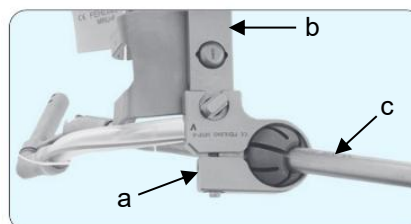

Fig. 18: Configuration example for MRP-6V

5) Ball joint adapter with eccentric lever



Fig. 19: MRO-0V

Ball joint adapter for fixation to the FEHLING MICS intercostal retractor MRP-1 and MRP-1F. This can be placed at any point on the toothed rack of the MRP-1/1F. The alignment of the ball is possible medially or laterally. The ball joint adapter can be attached to or detached from the toothed rack via the eccentric lever (black lever). For accommodating instruments with cylindrical shafts.

| Item no. | Ø in mm | Fixation of the movable ball |
|----------|---------|------------------------------|
| MRO-0 | 4 | Wing screw |
| MRO-0V | 4 | Cardan screwdriver |
| HTA-1 | 6.35 | Cardan screwdriver |



Fig. 20: MRR-1V

Ball joint adapter for accommodating the ball joint adapter with spacing lever (MRR-2, MRR-2V, MRR-2L, see section 6) *Ball joint adapter with spacing lever*, page 16) for attachment to the FEHLING MICS intercostal retractor MRP-1 and MRP-1F. This can be placed at any point on the toothed rack of the MRP-1/1F. The ball joint adapter can be attached to or detached from the toothed rack via the eccentric lever (black lever).

| Item no. | Ø in mm | Fixation of the movable ball |
|----------|---------|------------------------------|
| MRR-1 | 8 | Wing screw |
| MRR-1V | 8 | Cardan screwdriver |



Example configuration for ball joint adapter with eccentric lever

Figure 21 shows the ball joint adapter MRO-0V (a) as a configuration for retraction of the atrial roof. For this purpose, the ball joint adapter MRO-0V (a) was connected to the FEHLING MICS intercostal retractor MRP-1 (b) and equipped with a blade guide MRN-3 with cylindrical shaft (c).

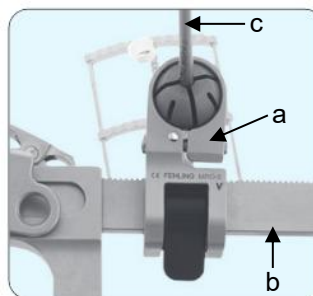

Fig. 21: Configuration example for MRO-0V

An example configuration for the ball joint adapter MRR-1V in combination with a ball joint adapter with spacing lever can be seen in Fig. 23 on page 17.

6) Ball joint adapter with spacing lever

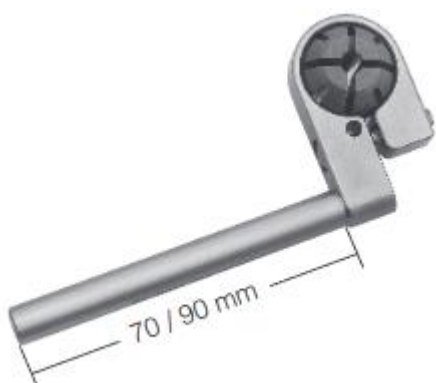

Fig. 22: MRR-2V, MRR-2L

The ball joint adapter serves as an extension if the desired position for the transthoracic atrial retractor cannot be reached with other ball joint adapters (e.g. MRO-0). A stepless extension of 20 to 25 mm is possible. Serves to accommodate instruments with cylindrical shaft. Fixation of the ball joint adapter possible by combination with MRR-1/ MRR-1V.

| Item no. | Ø in mm | Fixation of the movable ball |
|-------------------------------|---------|------------------------------|
| MRR-2V Spacing lever 70 mm | 4 | Cardan screwdriver |
| MRR-2L Spacing lever 90 mm | 4 | Cardan screwdriver |
| MRR-2 Spacing lever 70 mm | 4 | Wing screw |
| MRR-4 Spacing lever 70 mm | 8 | Wing screw |



Example configuration for ball joint adapter with spacing lever

Figure 23 shows the alternative option in case the intercostal incision was placed more postero-laterally and the desired position for the transthoracic atrial retractor can no longer be reached with the ball joint adapter MRO-0. The alternative is the combination of the ball joint adapter MRR-1 or MRR-1V (a) with the ball joint adapter with spacing lever MRR-2 (b). For this purpose, the ball joint adapter MRR-1V (a) was connected to the MICS intercostal retractor MRP-1 (c). The ball joint adapter with spacing lever MRR-2 (b) was attached with the aid of the ball joint adapter MRR-1V (a) and equipped with a blade guide MRN-3 with cylindrical shaft (d). In this way, the position of the transthoracic atrial retractor can be shifted medially by 20 to 25 mm.

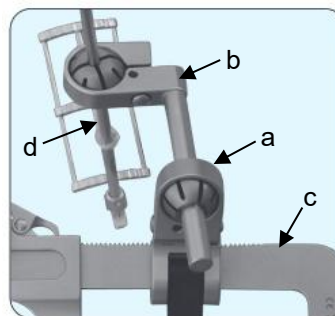

Fig. 23: Configuration example for MRR-2

Ball joint adapter with cloverleaf screw



Fig. 24: MRV-5

Ball joint adapter, 60°, angled, for accommodating instruments with cylindrical shafts. The ball joint adapter consists of a U-shaped profile that can be attached to rectangular retractor frames of different heights. The ball joint adapter is fastened using the attached cloverleaf screw. The MRJ-3 wrench (see section 8) *Required accessories*) is required for this cloverleaf screw.

| Item no. | Ø in mm | Fixation of the movable ball |
|----------|---------|------------------------------|
| MRV-5 | 8 | Cardan screwdriver |

Ball joint adapter for puncture incisions



Fig. 25: MRO-9

Ball joint adapter for separate puncture incision for placement and accommodation of instruments with cylindrical shaft.

| Item no. | Ø in mm | Fixation of the movable ball |
|----------|---------|------------------------------|
| MRO-1 | 4 | Eccentric lever |
| MRO-9 | 4 | Wing screw |
| MRO-9V | 4 | Cardan screwdriver |



Example configuration for ball joint adapter for puncture incision

Figure 26 shows the blade guide MRN-3 (a), which was inserted into the ball joint adapter MRO-9. Once the blade guide has reached the desired position, it is fixed by turning the wing screw of the ball joint adapter clockwise (c).

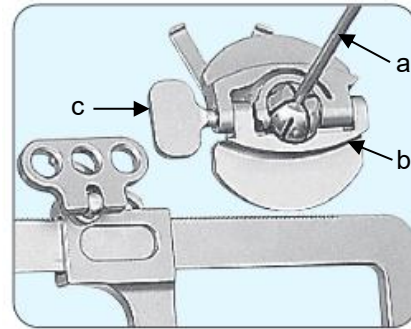

Fig. 26: Configuration example for MRO-9

Ball joint adapter for long shafts



Fig. 27: MTI-3

Ball joint adapter, round, for frontal accommodation of instruments with rectangular shafts. This can be attached via the two Y-shaped fixations.

| Item no. | Ø in mm | Fixation of the movable ball |
|----------|---------|------------------------------|
| MTI-3 | 5 | Wing screw |

Example configuration for holder for long shafts

Figure 28 shows the instrument for minimally invasive surgery with rectangular shaft (b) inserted in the ball joint adapter (a). Once the instrument has reached the desired position, it is secured by turning the wing screw of the ball joint adapter (c) clockwise.

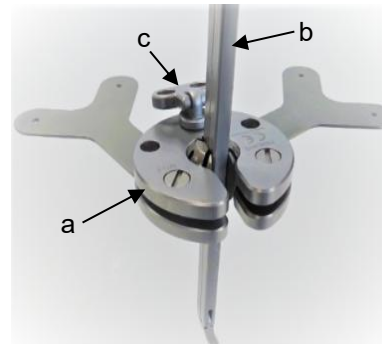

Fig. 28: Configuration example for MTI-3



8) Required accessories

A cardan screwdriver LMT-4 (Fig. 29) is required for the use of the ball joint adapters HTA-1, MRO-0V, MRO-9V, MRR-1V, MRR-2L, MRR-2V, MRR-5, MRP-5V, MRR-6, MRP-6V, MRU-8F, MRV-0F, MRV-0J, MRV-1F, MRV-5 and MRV-9F.

An Allen screwdriver TXW-9X (Fig. 30) is required for the use of the ball joint adapters MRX-5 and MSZ-2 to tighten or loosen the pressure screw.

A wrench for cloverleaf screws MRJ-3 (Fig. 31) is required for the application of the ball joint adapter MRV-5.

A corresponding slotted screwdriver is required for the assembly and disassembly of the fastening element.



Fig. 29: Cardan screwdriver LMT-4



Fig. 30: TXW-9X Allen screwdriver, 3 mm, sterilisable

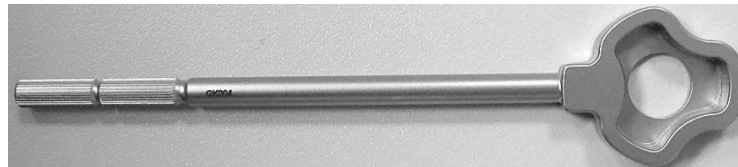

Fig. 31: Wrench for cloverleaf screws MRJ-3

9) Assembly

Please refer to section 7) *Configuration and application* for assembly of the ball joint adapter.

No assembly of the fastening elements is necessary.

10) Disassembly

Please refer to section 7) *Configuration and application* for disassembly of the ball joint adapter.

No disassembly of the fastening elements is necessary.

11) Obligation to report serious incidents

The user is obliged to report serious incidents which have occurred in connection with the medical device to the manufacturer either by e-mail to vigilance@fehling-instruments.de or via the complaint form at <https://www.fehling-instruments.de/en/complaint/> and to the competent authority of the Member State in which the user is domiciled.



| Symbols | | |
|---|--|-------------------|
| Where shown on the medical device, medical device label or instructions for use, the symbols have the following meanings according to DIN EN ISO 15223-1: | | |
| Manufacturer | Consult instructions for use or consult electronic instructions for use | Caution |
| Catalogue number | Batch code | Serial number |
| Medical device | Unique device identifier | CE marking |
| Oil can for points to be lubricated | CE marking | |
| Manufacturer's contact information | | |
| | FEHLING INSTRUMENTS GmbH Seligenstädter Str. 100 63791 Karlstein, Germany Tel.: +49 (0) 6188-9574-40 Fax: +49 (0) 6188-9574-45 E-mail: info@fehling-instruments.de www.fehling-instruments.de | |